

CROWN X

10E4DG/DW22

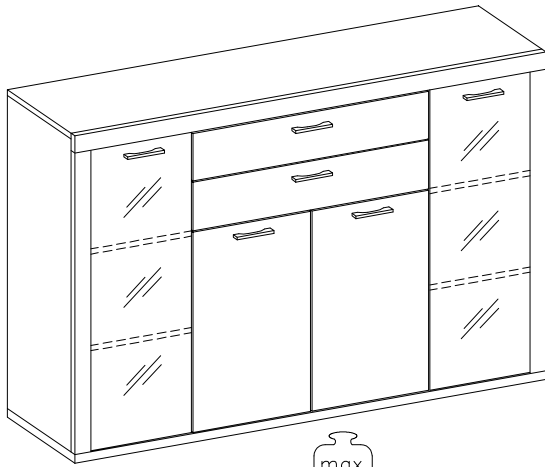

#	ART. NR	L	W	T	Q	Col.No
1	3761	1197	430	16	1	1
2	3762	1197	430	16	1	1
3	3763	1197	411	16	1	1
4	3764	1197	411	16	1	1
5	3766	815	115	16	2	1
6	3711	1135	70	16	2	1
7	3771	426	1212	2,5	2	1
8	3772	432	1212	2,5	2	1
9	3774	1135	376	4	2	1
10	3768	880	185	16	2	2
11	3710	438	756	16	2	3
12	3760	1738	430	16	1	2
13	3751	350	140	16	2	2
14	3752	350	140	16	2	2
15	3767	1738	450	16	1	2
16	3770	1738	70	19	1	2
17	3773	829	358	2,5	2	2
18	3765	854	411	16	1	2
19	3775	854	411	6	1	2

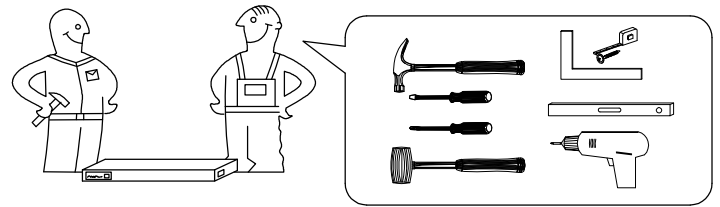
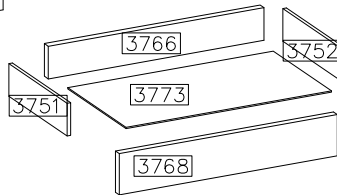
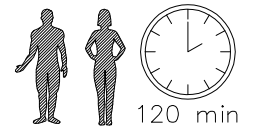
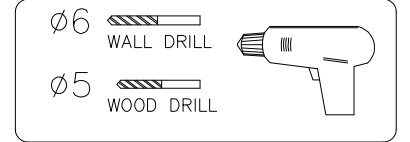
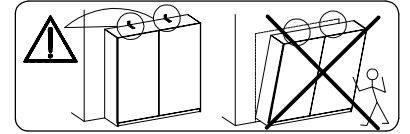
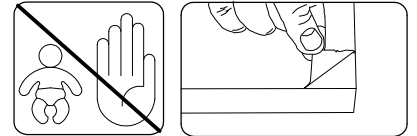
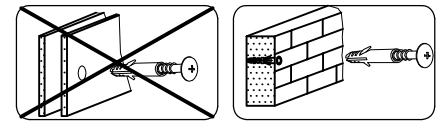
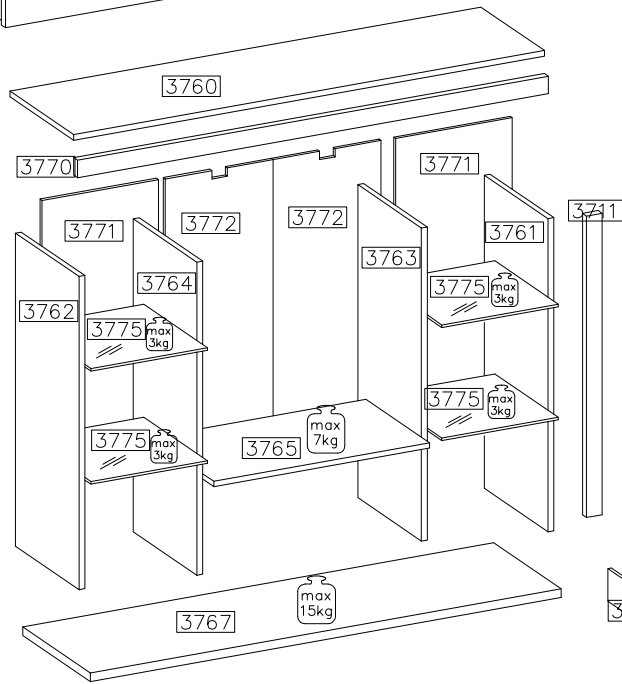
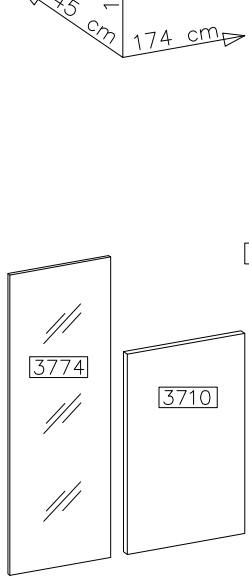
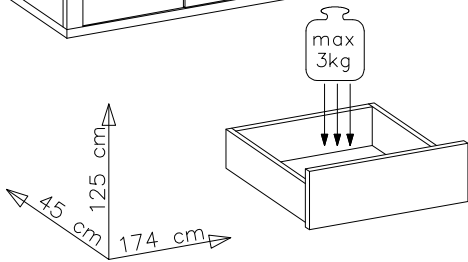
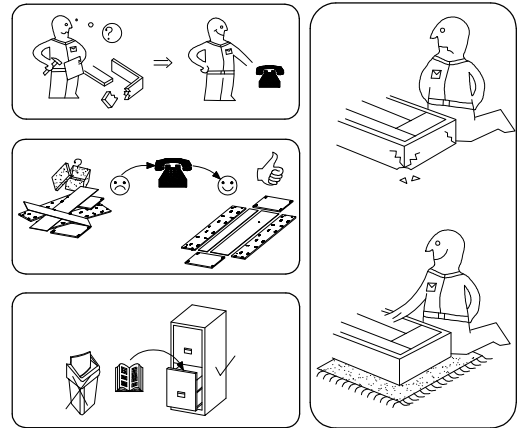

A	B	C	D1	E	E1	F4	F8	G6	H4	P7
28	8	15	15	15	8	6	14	10	10	4
L	J4	J5	N	O	P3	P4	P9	S1	U	P1
14	4	20	2	1	24	2	28	6	8	28
V2	V1	PR1	Z	R3	R2	J8	J9	P8		
4	1	2KPL	2	4	8	10	4	10		

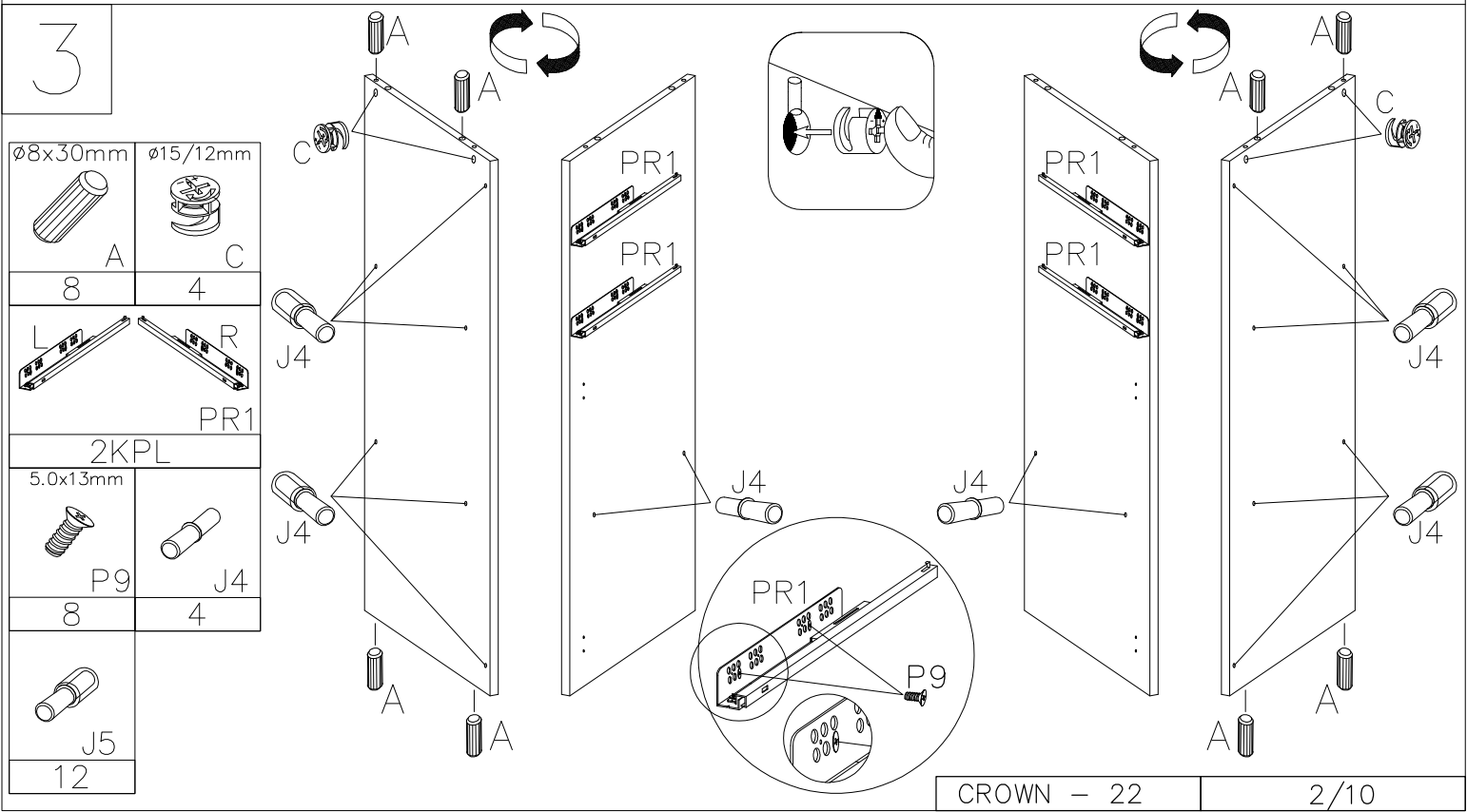
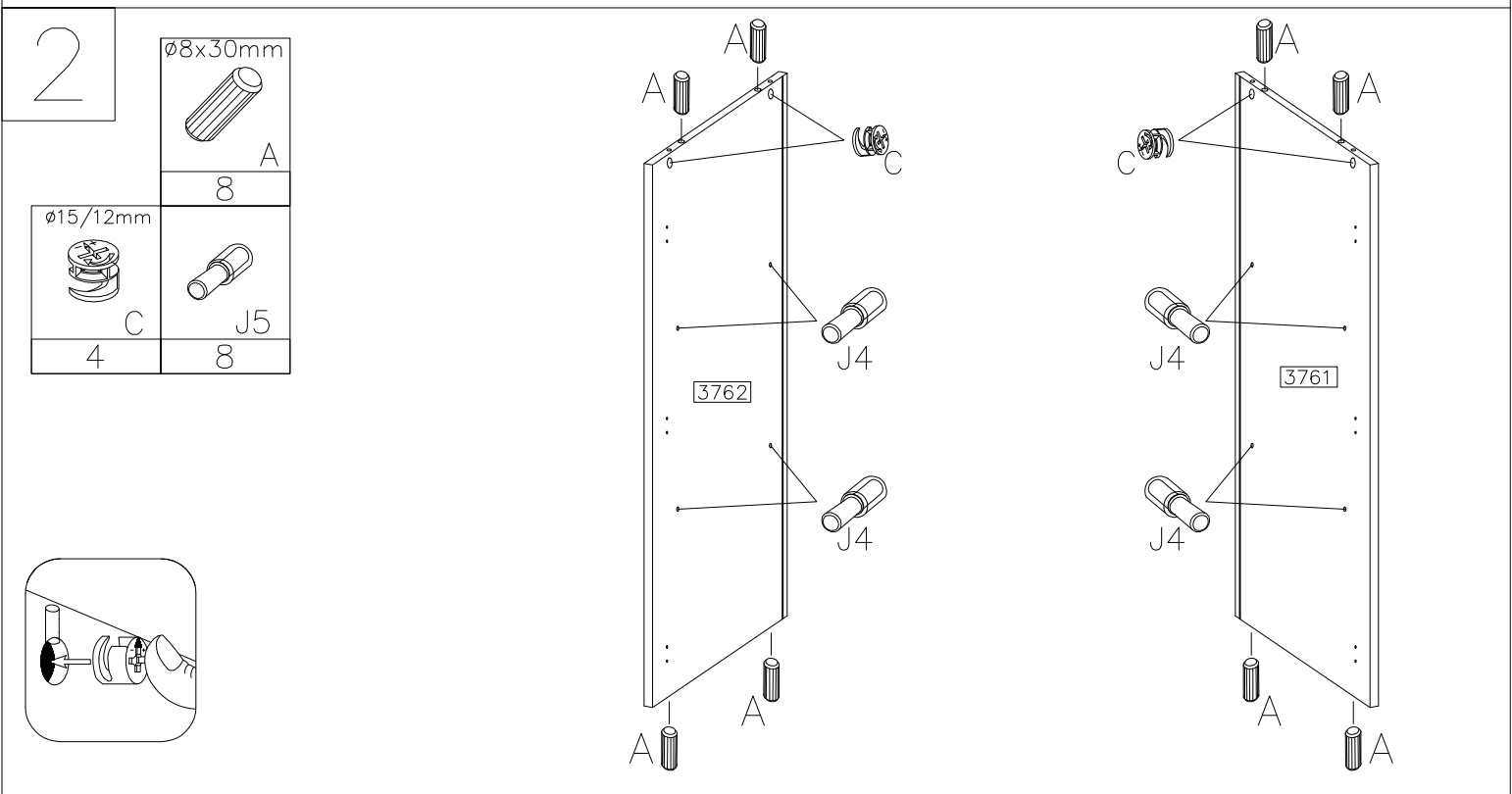
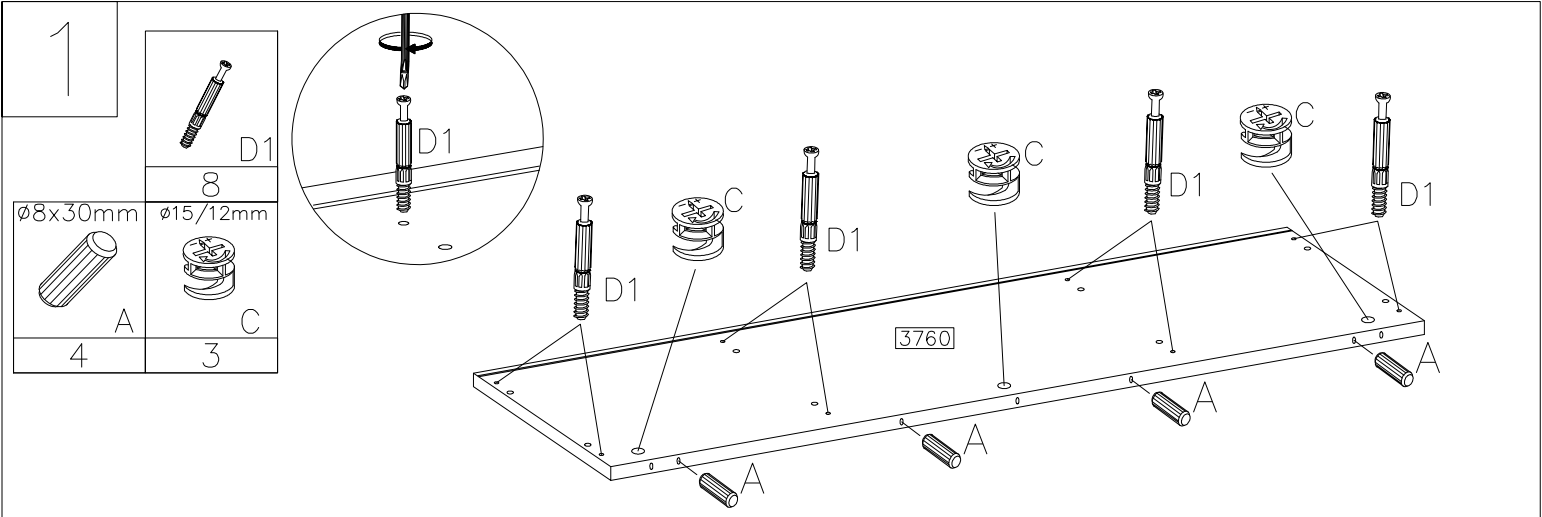

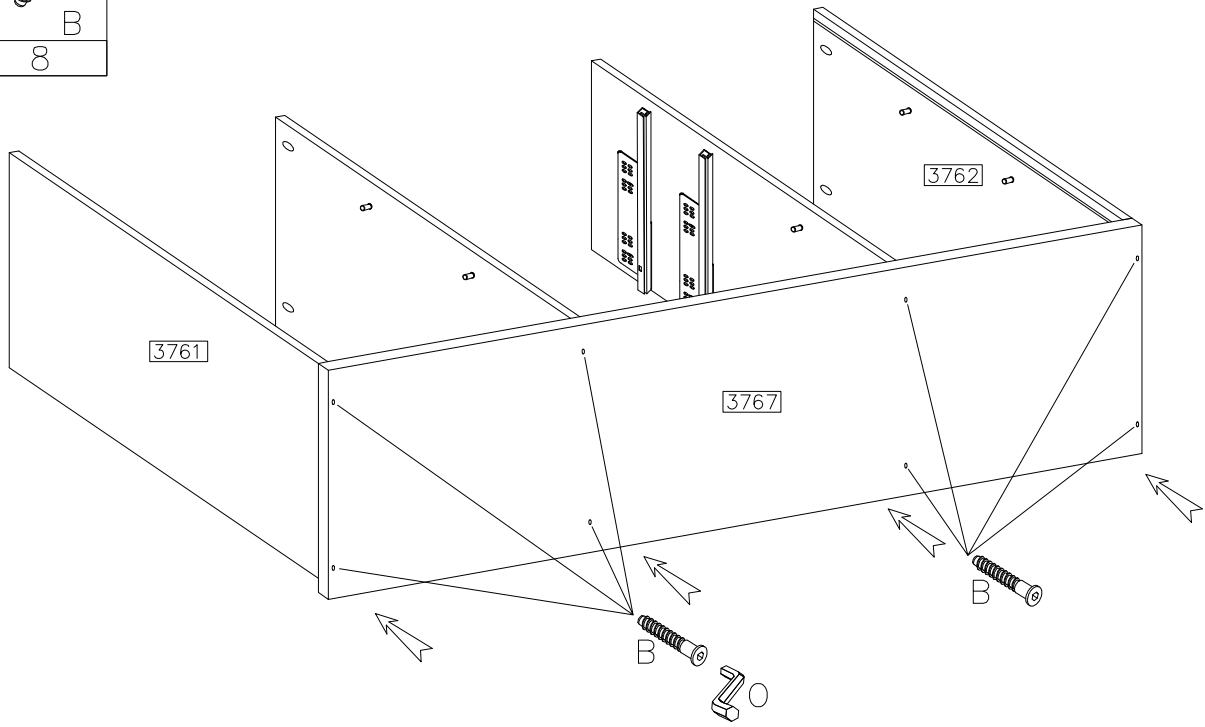
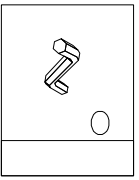
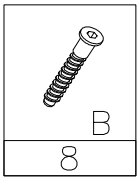

4

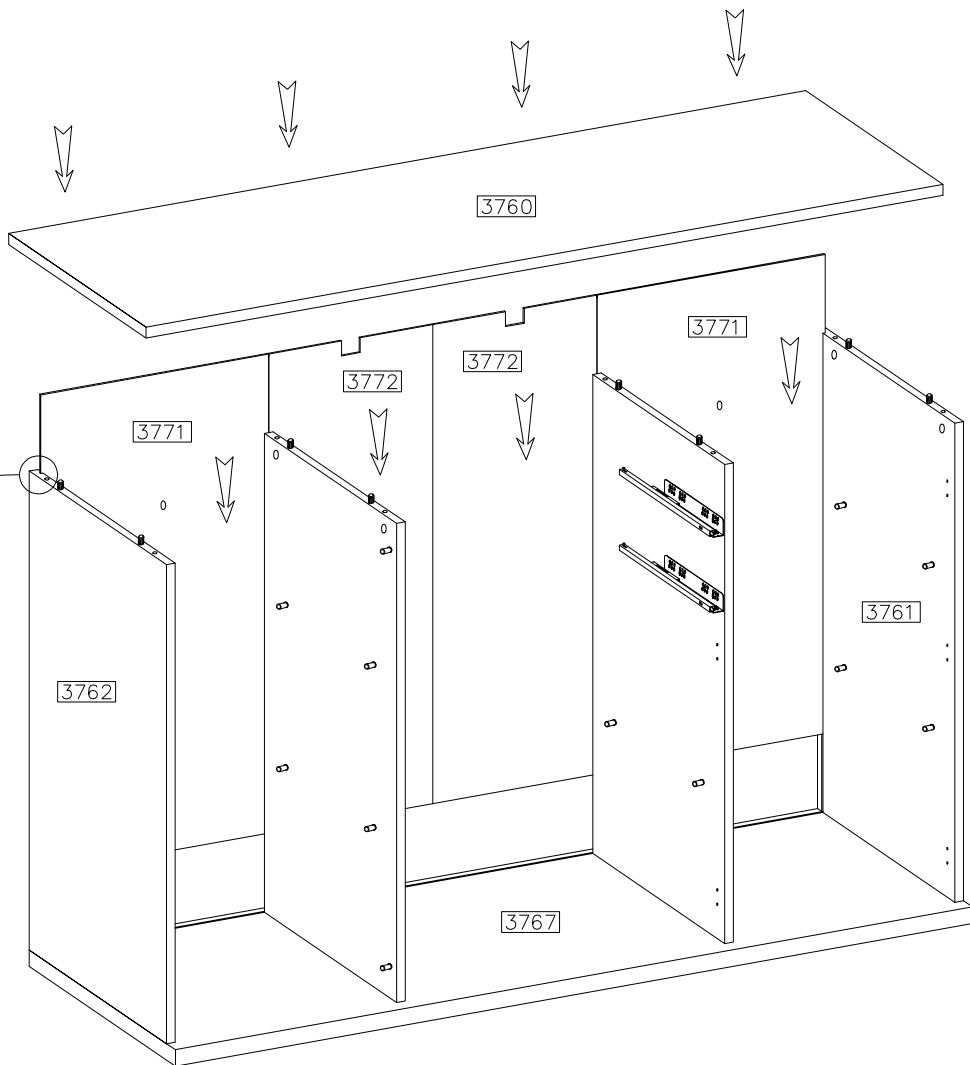
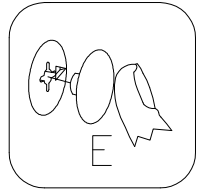
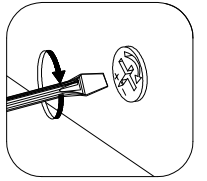
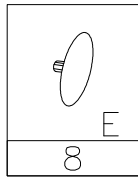

5



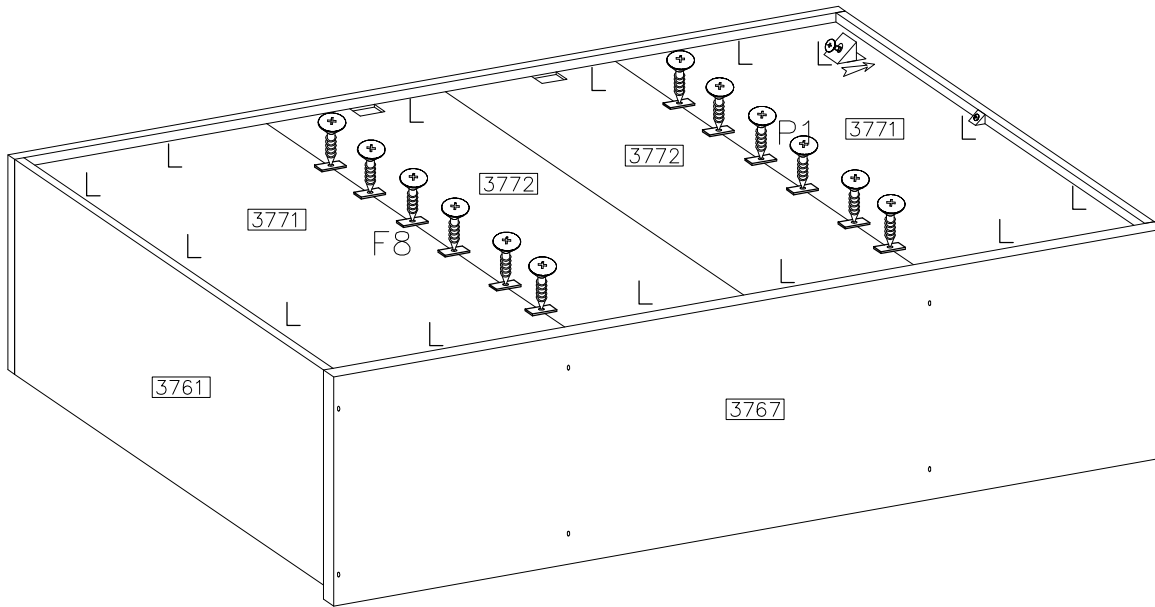
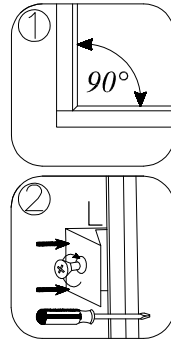

6

	$\varnothing 3.0 \times 16 \text{mm}$ 	
F8	P1	L
14	14	14

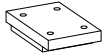

7

	$\varnothing 4.0 \times 30 \text{mm}$ 
F4	P3
6	24

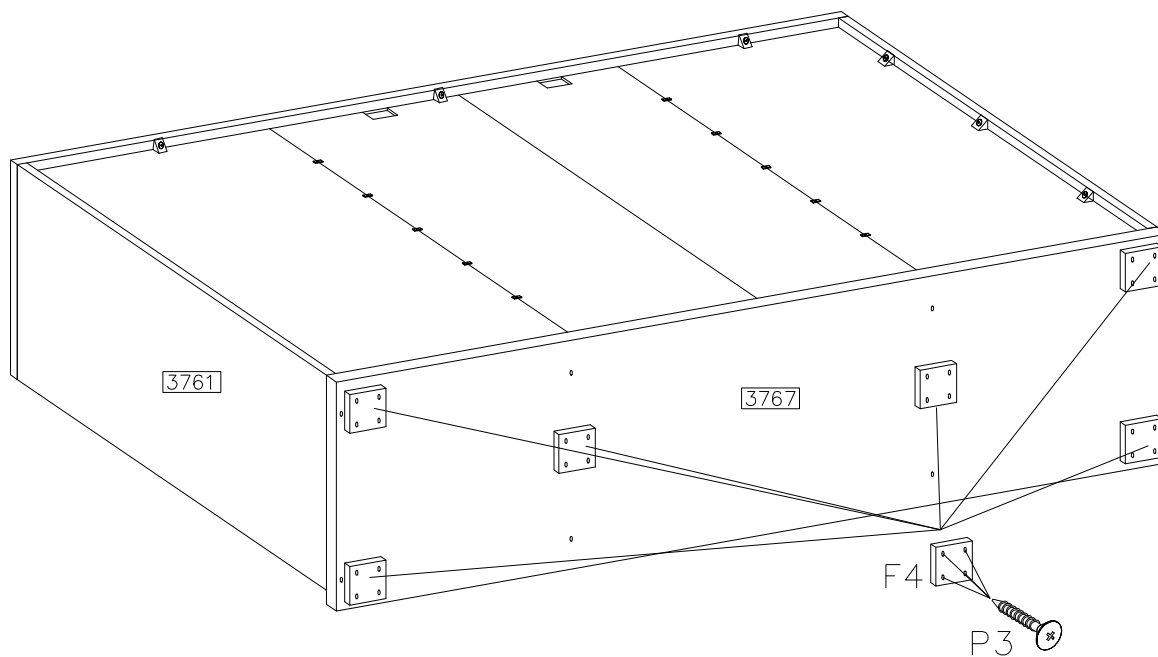
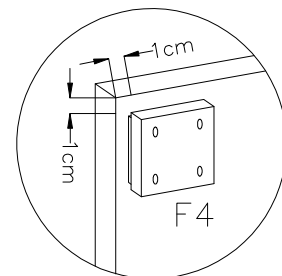

8

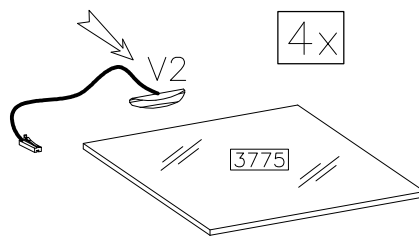
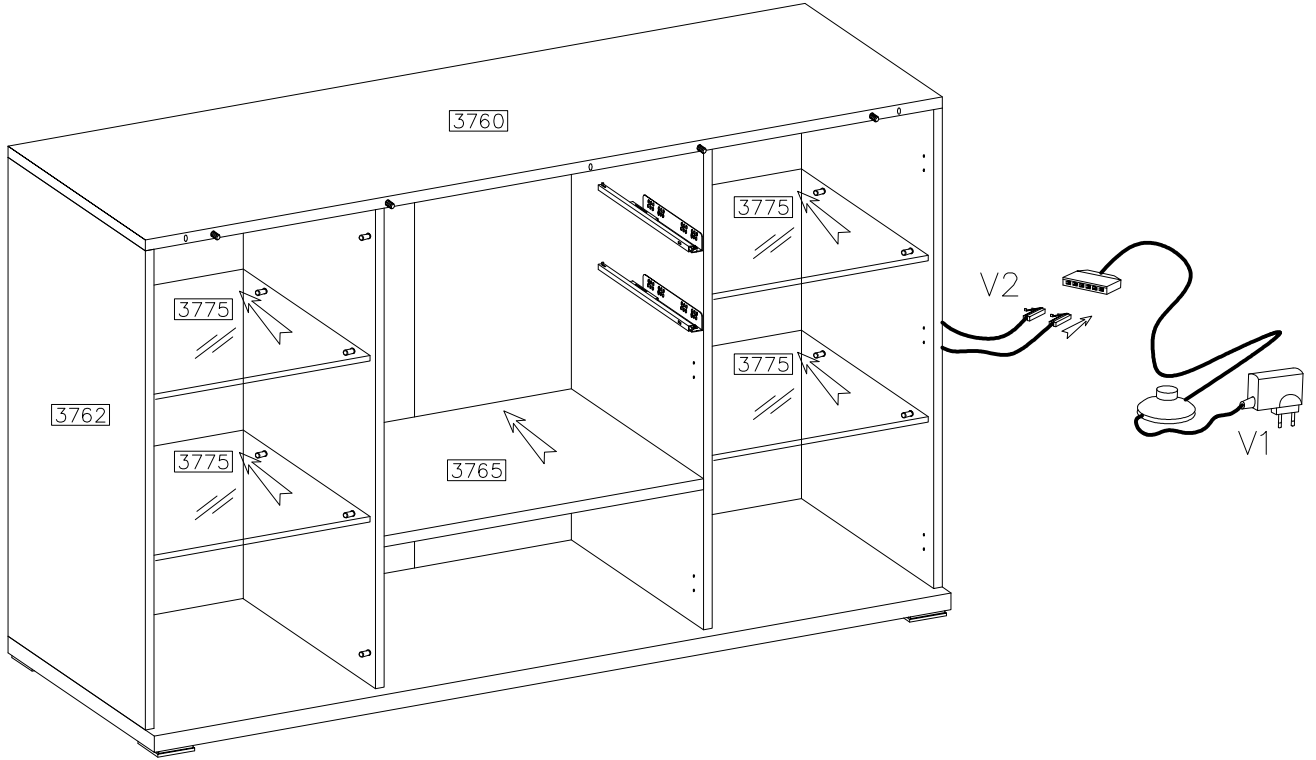
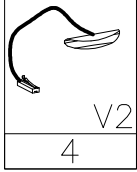
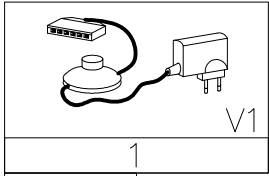

9

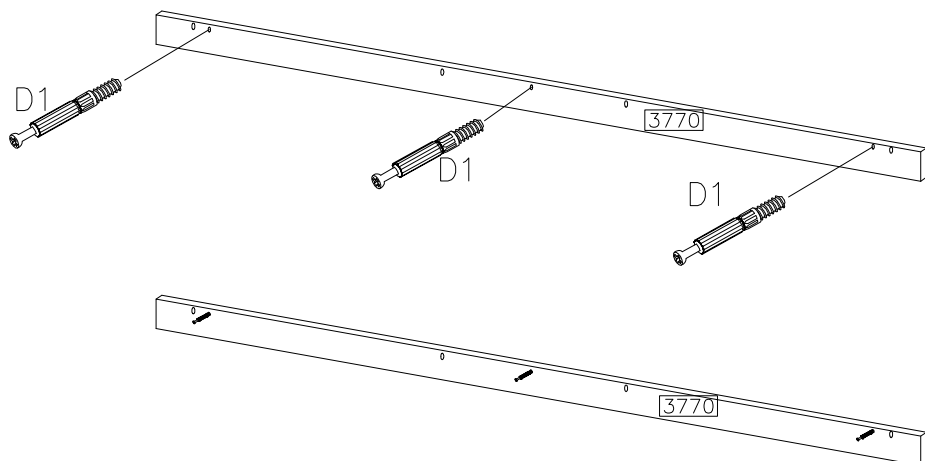
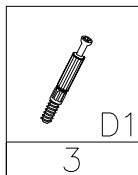

10

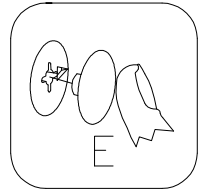
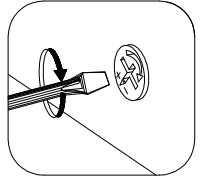
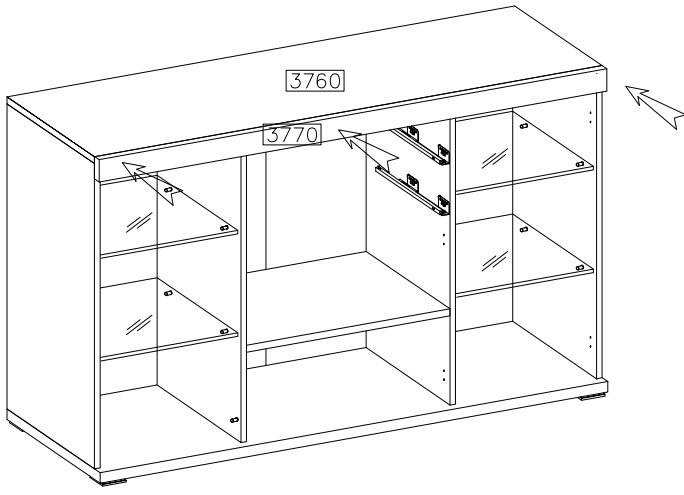
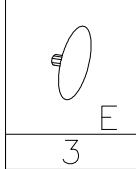

11

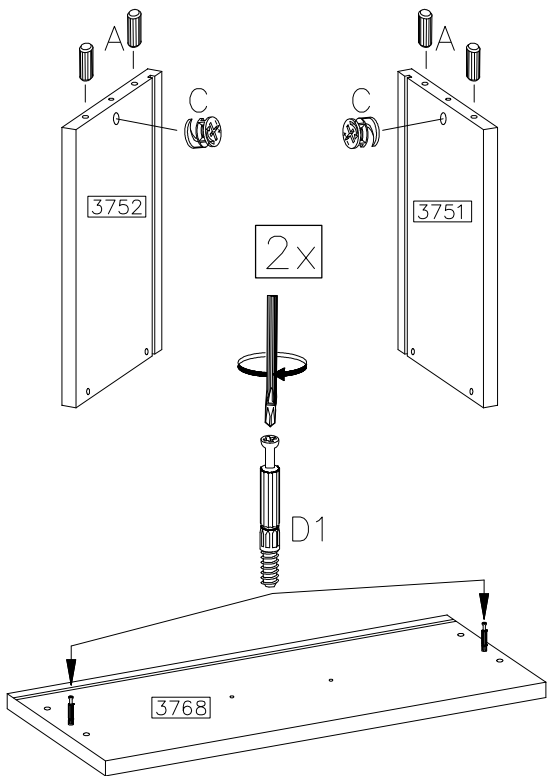
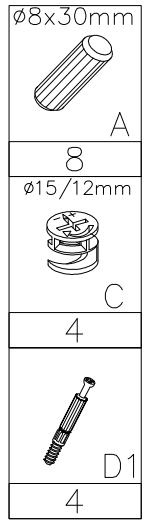

12

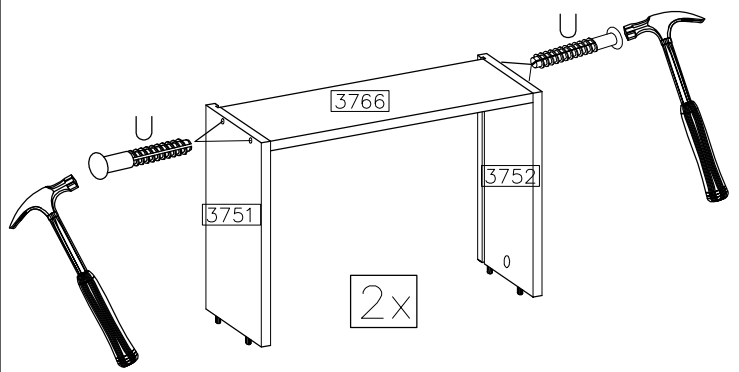
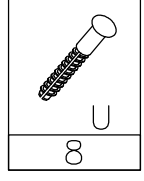

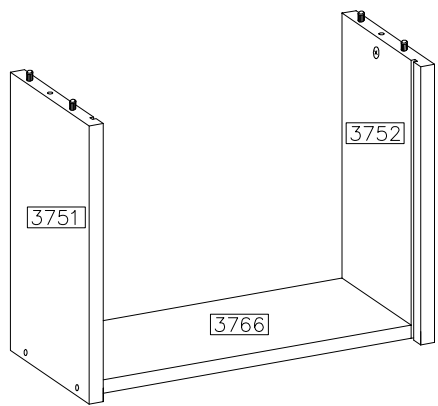
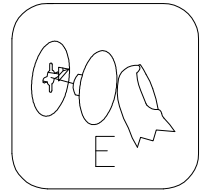
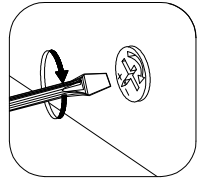
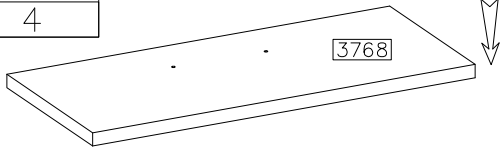
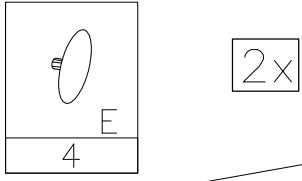

13

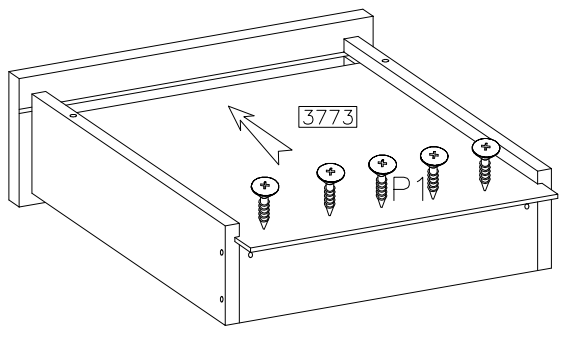
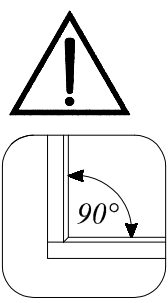
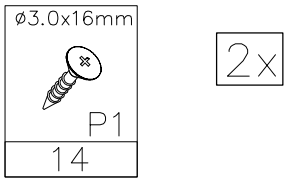

14



15



	M4.0x22mm 
S1	R2
2	4

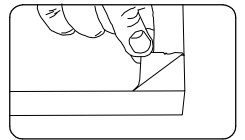
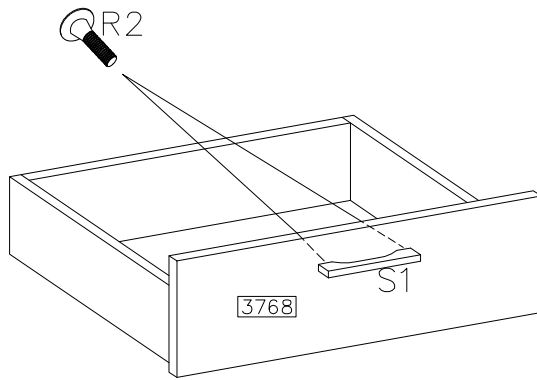

2x



16

5.0x13mm 
P9
8





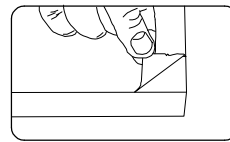

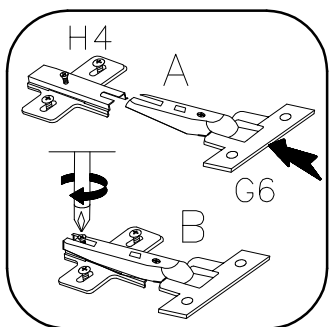
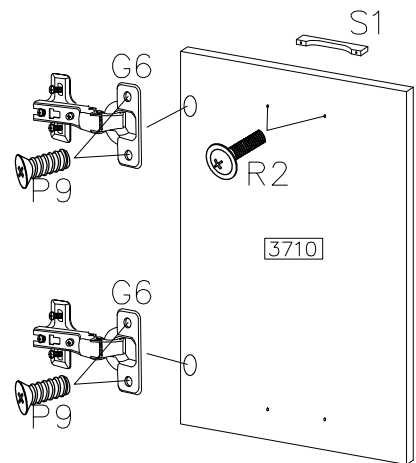
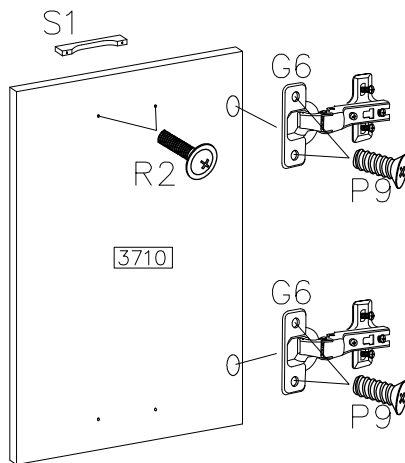
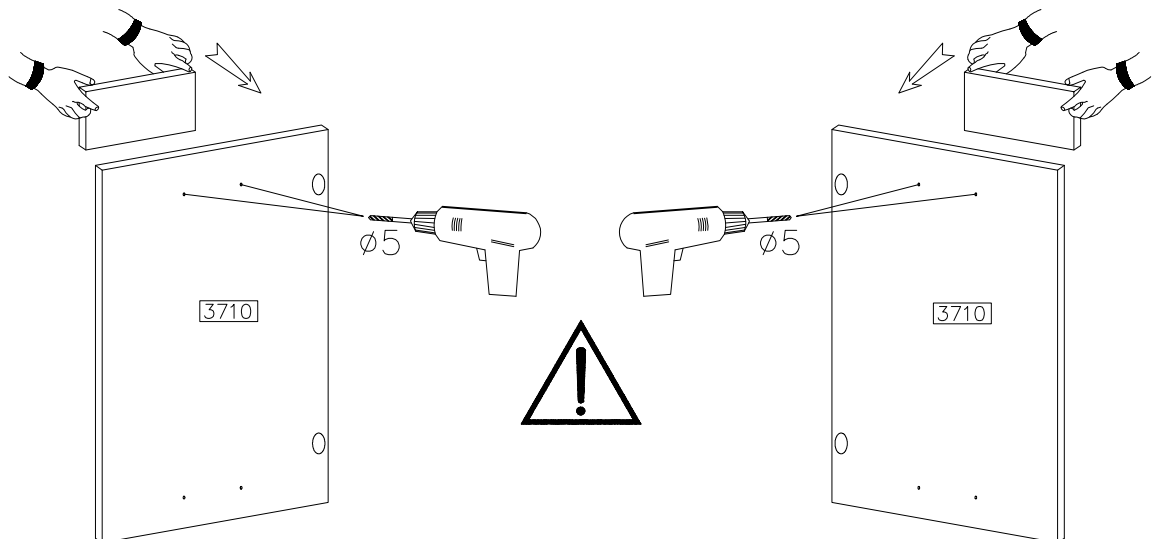

	M4.0x22mm 
S1	R2
2	4

H=0 	ø35/KR-0 
H4	G6
4	4



Ø5  WOOD DRILL 



<p>∅8</p>  <p>J8</p>	<p>∅6</p>  <p>J9</p>	<p>∅4.0x16mm</p>  <p>P8</p>
<p>10</p>  <p>G6</p>	<p>4</p> <p>H=0</p>  <p>H4</p>	<p>10</p>  <p>S1</p>
<p>6</p> <p>M4.0x12mm</p>  <p>R3</p>	<p>6</p> <p>∅5.0x13mm</p>  <p>P9</p>	<p>2</p>
<p>4</p>	<p>12</p>	

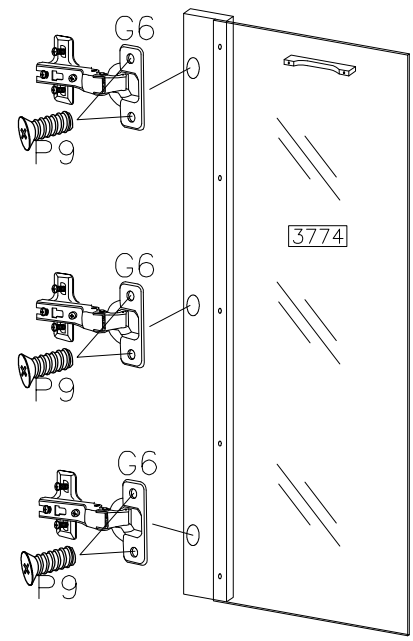
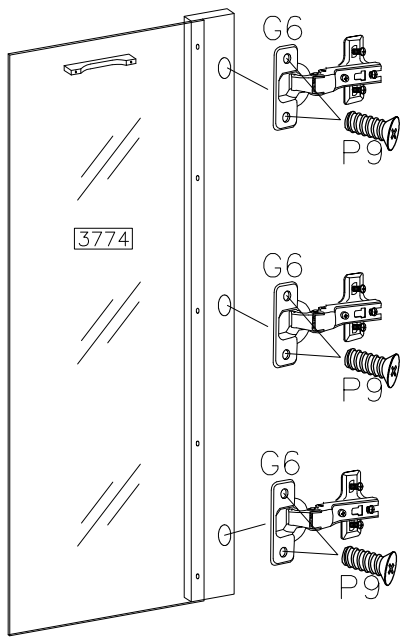
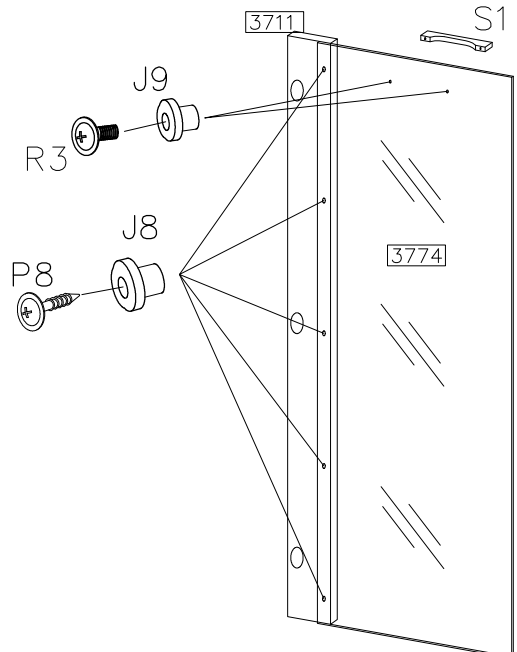
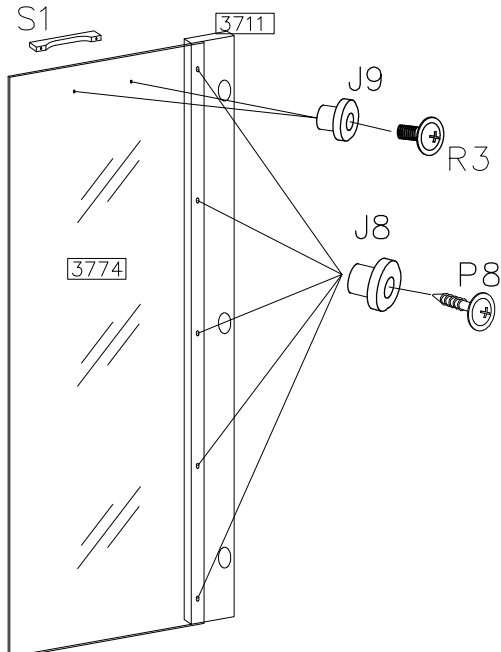
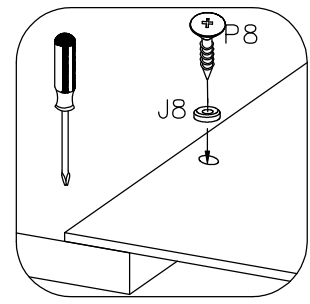
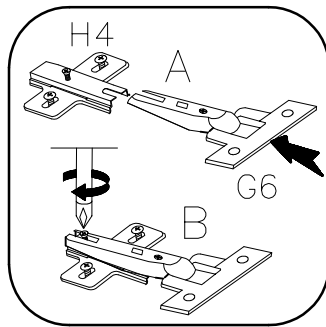
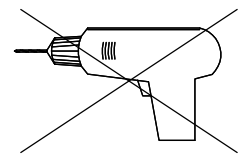

∅3.0x20mm





P7

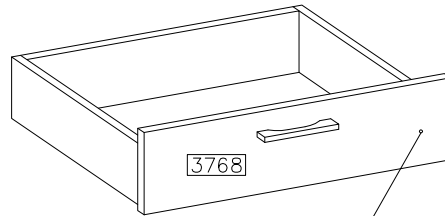
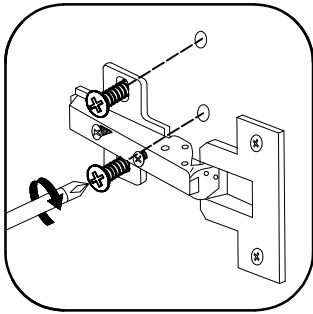
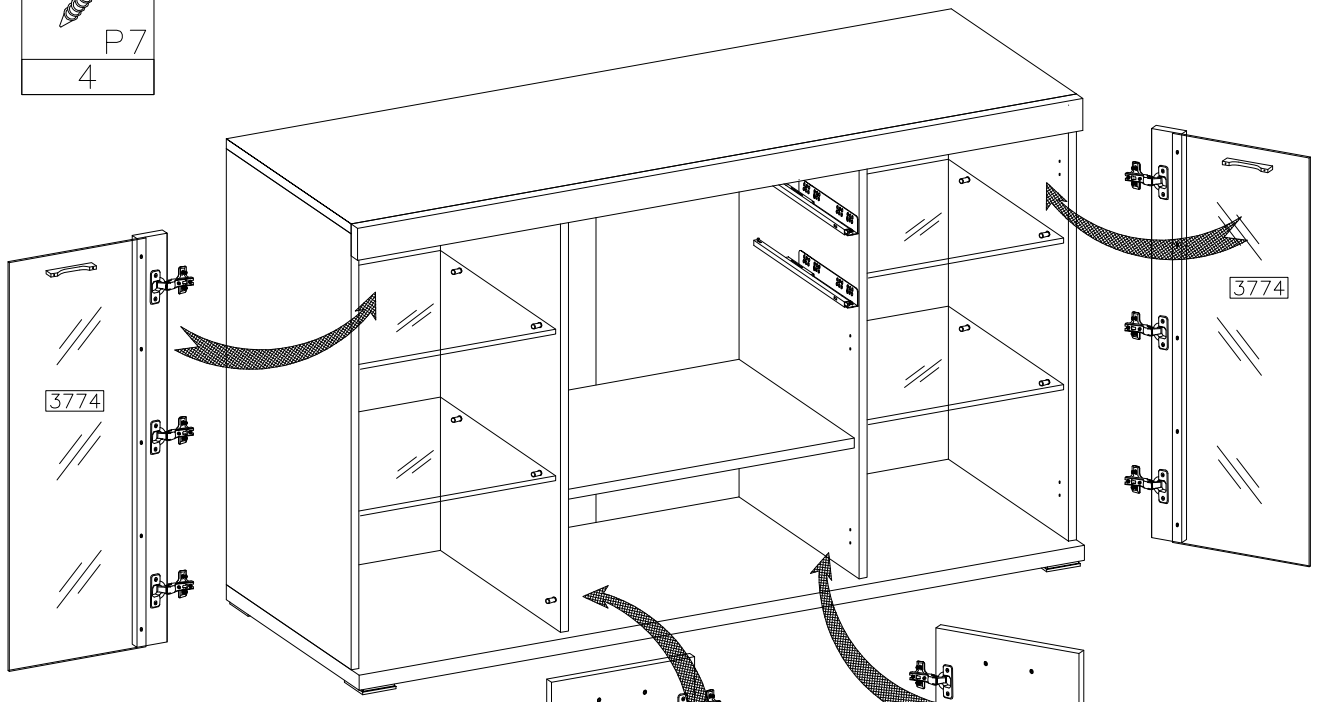



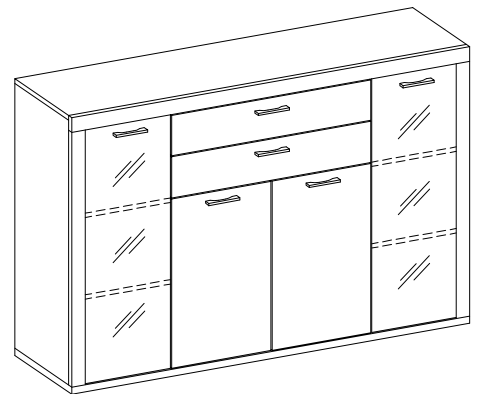
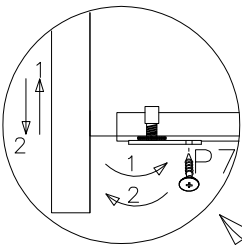
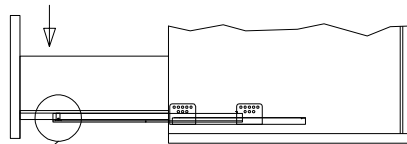
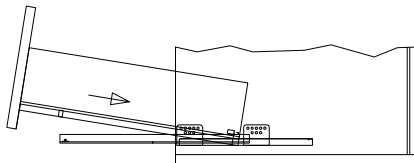

4



2x



<p>Ø6.0x50mm</p>  <p>Z</p>
2

<p>Ø6</p>  <p>WALL DRILL</p>	<table border="1"> <tr> <td> <p>Ø3.5x16mm</p>  <p>P4</p> </td> <td>  <p>N</p> </td> </tr> <tr> <td>2</td> <td>2</td> </tr> </table>	<p>Ø3.5x16mm</p>  <p>P4</p>	 <p>N</p>	2	2
<p>Ø3.5x16mm</p>  <p>P4</p>	 <p>N</p>				
2	2				
